

SECTION B

FUEL PUMP ALL SERIES

CONTENTS

Division	Subject	Paragraph
I	TROUBLE DIAGNOSIS: Fuel Pump Inspection and Test	64-9
	Fuel Pump Trouble Diagnosis	64-10
II	DESCRIPTION AND OPERATION: Description and Operation of Fuel Pump	64-11
III	ADJUSTMENTS AND MINOR SERVICE: (Not Applicable)	
IV	REMOVAL AND INSTALLATION: Mechanical Fuel Pump Removal and Installation	64-12
V	OVERHAUL AND MAJOR SERVICE: (Not Applicable)	-
VI	SPECIFICATIONS: (Not Applicable)	-

DIVISION I

TROUBLE DIAGNOSIS

64-9 FUEL PUMP INSPECTION AND TEST

If the fuel system is suspected of delivering an improper amount of fuel to the carburetor, it should be inspected and tested in the car, as follows:

a. Inspection of Fuel System

1. Make certain that there is gasoline in the tank.
2. With engine running, inspect for leaks at all gasoline feed hose connections from fuel tank to carburetor. Tighten any loose connections. Inspect all hoses for flattening or kinks which would restrict the flow of fuel. *Air leaks or restrictions on suction side of mechanical fuel pump will seriously affect pump output.*
3. Inspect for leaks at fuel pump diaphragm flange (mechanical pump only).
4. Disconnect feed pipe near carburetor. Ground distributor terminal of coil with jumper wire so that engine can be cranked without firing. Place suitable container at end of pipe and crank engine a few revolutions. If no gasoline, or only a little flows from pipe, the feed line is clogged or fuel pump is inoperative. Before condemning the fuel pump, disconnect feed line at both ends and blow through it with air hose to make sure that it is clear.
5. If gasoline flows in good volume from pipe at carburetor it may be assumed that the fuel pump and feed line are okay; however, it is advisable to make the following pressure and volume tests to make certain that fuel pump is operating within specifications.

b. Fuel Pump Pressure Test

1. Disconnect gasoline line near carburetor and connect a suitable pressure gage (such as Pressure-Leakdown Tester J-22109).
2. Start engine and check pressure with engine running at slow idle speed. Fuel pump pressure on 250 and 350 engines should be 3 lbs. minimum; on 455 engines it should be 4 1/2 lbs. minimum. On cars equipped with a vapor return system, squeeze off the return hose so that an accurate reading can be obtained.
3. If fuel pump pressure is below minimum, pump must be replaced.

c. Fuel Pump Flow Test

1. Disconnect fuel line from carburetor. Run fuel line into a suitable measuring container.

2. While observing the sweep second hand of a clock or watch, run the engine at idle until there is one pint of fuel in the container. One pint should be pumped in 30 seconds or less.

3. If flow is below minimum, check for a restriction in the line.

64-10 FUEL PUMP TROUBLE DIAGNOSIS

Complete diagnosis of all possible causes of the trouble prior to replacement of the fuel pump will save time, expense and possibly prevent a repeat complaint.

a. Low Pressure Complaint

The only way to check fuel pump pressure is by connecting an accurate pressure gauge to the fuel line at carburetor level. Never replace a fuel pump without first making this simple check. See Paragraph 64-9, b.

b. Not Enough Fuel Flow Complaint

When an engine has a "starving-out" condition, many mechanics jump to the conclusion that the fuel pump is not pumping enough fuel. Many times the "starving" condition is actually due to a weakness in the ignition system, since these two troubles are very hard to separate. Even when an engine is starving for fuel, the cause is more likely to be a plugged fuel filter or a restricted fuel line than a defective fuel pump. See Paragraph 64-9, c.

DIVISION II

DESCRIPTION AND OPERATION

64-11 DESCRIPTION AND OPERATION OF FUEL PUMPS

a. Description of Mechanical Pump

An AC fuel pump is used on all engines. The pump assembly is mounted on the timing chain cover in an inverted position, and the pump rocker arm is actuated by an eccentric mounted on front end of the camshaft.

The fuel pump is a diaphragm type pump and is actuated by the rocker arm through a link and a pull rod. See Figure 64-11.

b. Operation of Mechanical Fuel Pump

The fuel pump draws gasoline from the tank and supplies it to the carburetor in sufficient quantity to meet engine requirements under all operating conditions. The principal parts of the fuel pump are shown in Figure 64-11.

The rocker arm spring holds the rocker arm in constant contact with the eccentric on the engine camshaft so that the rocker arm swings up and down as the camshaft rotates. As the arm swings downward, it bears against a

shoulder on the link which is pivoted on the rocker arm pin. The link swings upwards, thereby pulling the fuel diaphragm upward by means of the connecting pull rod.

Upward movement of the fuel diaphragm compresses the diaphragm spring and also creates a vacuum in the fuel chamber under the diaphragm. The vacuum causes the outlet valve to close and causes fuel from the gasoline tank to enter the fuel chamber through the inlet valve.

As the rotating eccentric permits the rocker arm to swing upward, the arm releases the fuel link; it cannot move the link downward. The compressed diaphragm spring then exerts pressure on the diaphragm and the fuel in the chamber below diaphragm. This pressure closes the inlet valve and forces fuel out through the outlet valve to the carburetor.

Since the fuel diaphragm is moved downward only by the diaphragm spring, the pump delivers fuel to the carburetor only when the pressure in the outlet line is less than the pressure maintained by the diaphragm spring. The condition arises when the carburetor float needle valve is not seated and the fuel passage from the pump into the carburetor float chamber is open. When the needle valve is closed and held in place by the pressure of the fuel on the float, the pump builds up pressure in fuel chamber until it overcomes the pressure of the diaphragm spring. This pressure results in almost complete stoppage of diaphragm movement until more fuel is needed.

The air space in the bottom of the fuel pump provides a pocket in which fuel under pressure can compress a certain volume of air. When the pressure is relieved (pump on suction stroke) the pocket of compressed air pushes the fuel on to its destination. The air pocket minimizes flow variation experienced with two-cycle pump stroke and increases the pump output.

d. Fuel Pump Repairs

Because fuel pump covers for both mechanical pumps are crimped onto the pump body at the factory, it is not possible to disassemble the pump for any repairs.

If a fuel pump fails to pass the following tests and the failure is found to be the fault of the pump, the fuel pump must be replaced with a new one.

DIVISION IV

REMOVAL AND INSTALLATION

64-12 MECHANICAL FUEL PUMP

a. Mechanical Fuel Pump Removal

1. Disconnect fuel inlet hose from pump. Disconnect vapor return hose, if so equipped.
2. Disconnect fuel outlet pipe.

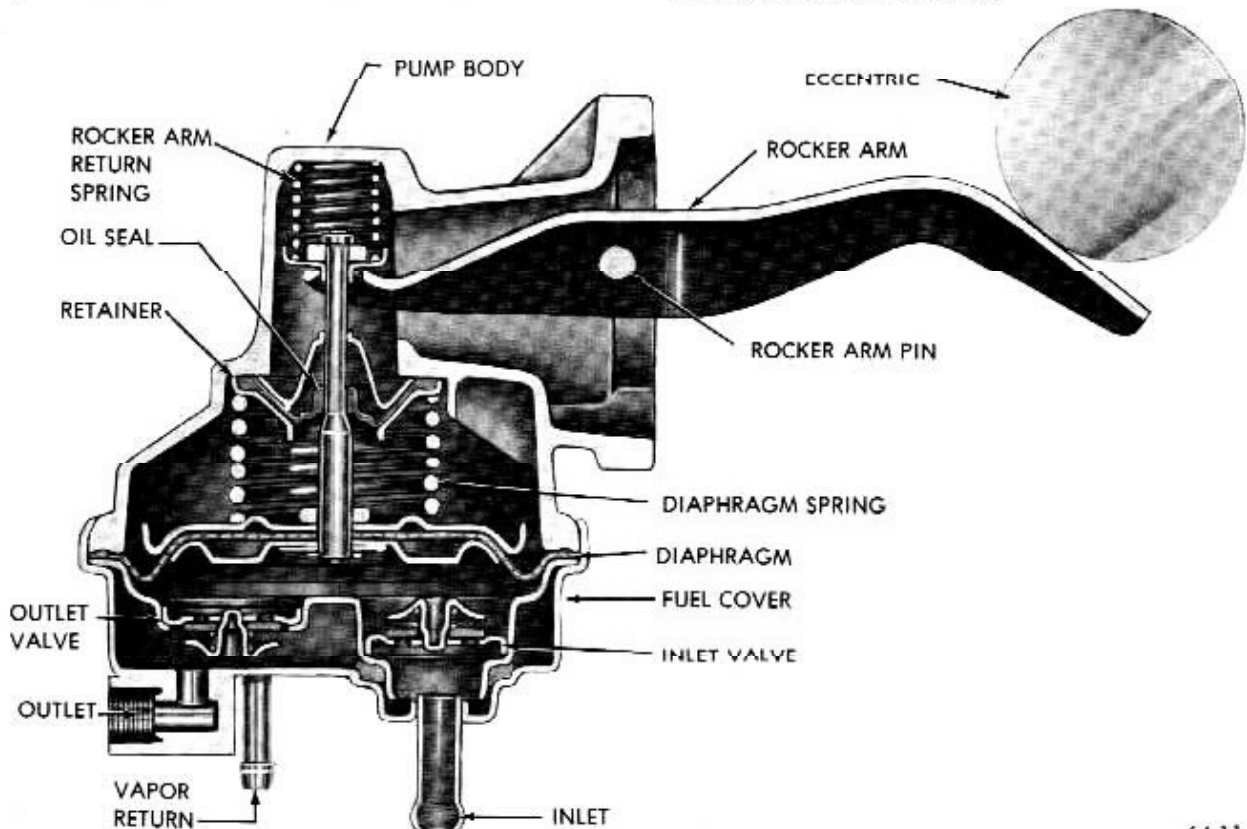

Figure 64-11 - Fuel Pump

3. Remove two 1/2 inch hex head bolts, using a 3/8 inch drive deep socket and a ratchet handle.

4. Remove old fuel pump.

b. Mechanical Fuel Pump Installation

1. Install new fuel pump with new gasket.

2. Install two 1/2 inch hex head bolts, driving them in alternately and evenly.

3. Install fuel outlet pipe. If it is difficult to start fitting, time can be saved by disconnecting upper end of pipe from carburetor. Tighten fitting securely, meanwhile holding fuel pump nut with a wrench. Install and tighten fitting at carburetor, if removed.

4. Install fuel inlet hose. Install vapor return hose, if so equipped.

5. Start engine and check for leaks.

ALL LINES AND CONNECTIONS MUST BE FREE OF LEAKS UNDER OPERATING CONDITION.

NOTE: ORIENT CLAMP TANGS SO THAT THEY CANNOT CONTACT ADJACENT HOSES.

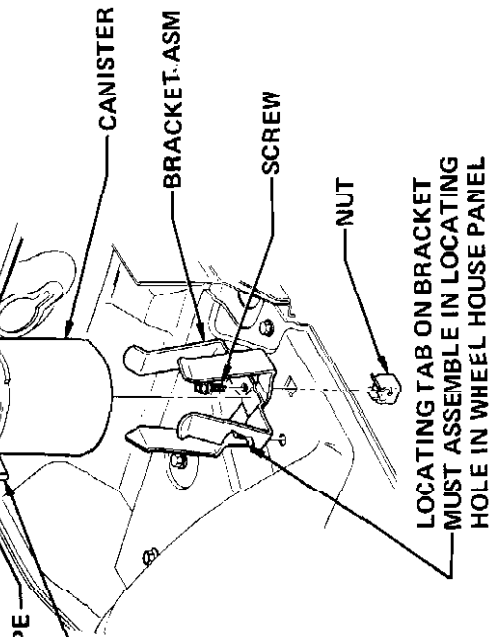

1 HOSE - CANISTER TO EVAP PIPE

1 HOSE - CANISTER TO CARB

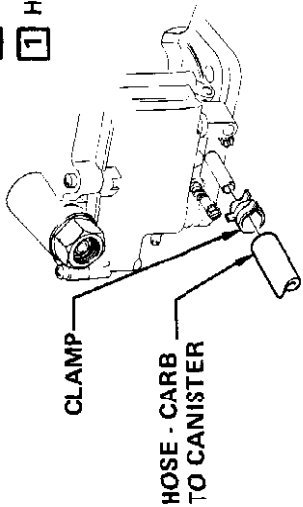

VIEW OF CONNECTION ON
350 CU IN ENGINE
2 BBL

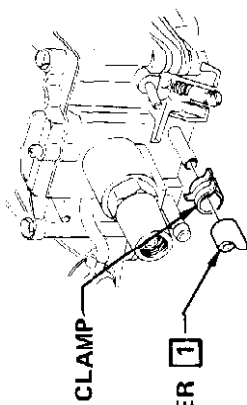
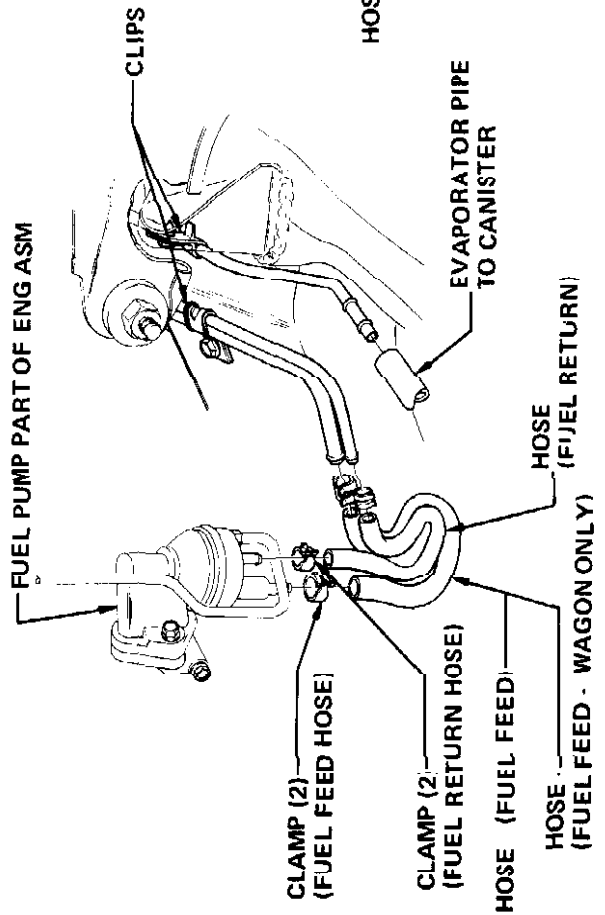

VIEW OF CONNECTION ON
455 CU IN ENGINE
350 CU IN ENGINE 4 BBL

Figure 64-12 - Carburetor, Fuel Pump, and Canister Hose Connections